

LOC	DIST	REVISIONS					
CM	00	P	LTR	DESCRIPTION	DATE	DWN	APVD
		D		ECO-07-007260	09APR07	KW	DB

1. DIMENSION IN BRACKET ARE IN INCHES.

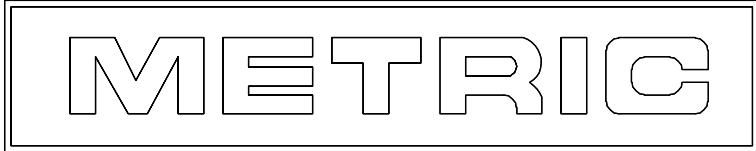
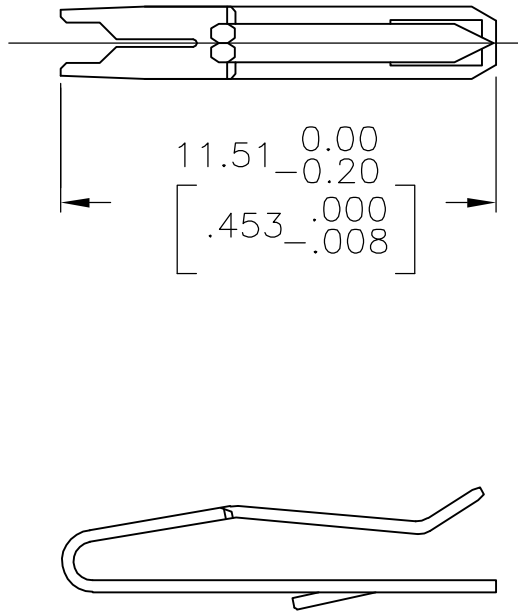

TIN	641646-2
TIN-LEAD	641646-1
FINISH	PART NO

RELEASED FOR PUBLICATION

ALL RIGHTS RESERVED.

BY TYCO ELECTRONICS CORPORATION.

© COPYRIGHT

THIS DRAWING IS UNPUBLISHED.

DIMENSIONS: mm [INCHES]	DWN L. SMITH	20JAN94	MATERIAL	0.30[.012] THK COPPER ALLOY	FINISH	MATTE TIN OR BRIGHT TIN LEAD 0.00203[.000080] MIN THK
	CHK R. SWING	20JAN94	Tyco Electronics Corporation Harrisburg, PA 17105-3608			
TOLERANCES UNLESS OTHERWISE SPECIFIED:	APVD E. BEILES	27JAN92				
0 PLC ± -	PRODUCT SPEC	NAME CONTACT, 0.36-0.51 [.014-.020] POST LOOSE PEICE 28 AWG WIRE, MTA-100				
1 PLC ± -	APPLICATION SPEC					
2 PLC ± -	WEIGHT	SIZE CAGE CODE DRAWING NO RESTRICTED TO				
3 PLC ± -		A4 00779	C-641646	-		
4 PLC ± -		CUSTOMER DRAWING				SCALE 5:1
ANGLES ± -						SHEET 1 OF 1
						REV D